

## UTiFLEX<sup>®</sup> Flexible Cable Assemblies: Power Handling

### **Background**

UTiFLEX cable assemblies were tested for CW high power handling capability. The primary purpose of the test was to ensure the ability of the selected cable assemblies to withstand exposure to high power levels and still function per specification. The secondary purpose of the test was to determine external cable and connector temperature relative to power input.

**Process:** The following UTiFLEX cable assemblies were selected for test:

<b><u>Serial Number</u></b>	<b><u>Description</u></b>
96H1761	UFA 210B-0-0600-300300
96H1758	UFA 147A-0-0600-504504
96H1755	UFB 311A-0-0600-504504
96H1762	UFA 210B-0-0600-504504
96H1760	UFA 210B-0-0600-504504
96H1763	UFA 210B-0-0600-504504
96H1765	UFA 210A-0-0600-504504
96H1764	UFA 210B-0-0600-300300
96H1766	UFA 210B-0-0120-300300
96H1757	UFB 311A-0-0600-603603

All test specimens included in this test were first tested for insertion loss and VSWR performance and were determined to meet Micro-Coax specifications.

Each test specimen had (9) thermocouples attached along the length of the assembly. One thermocouple was attached to the input connector and one to the output connector. The remaining thermocouples were attached to the cable assembly in one foot increments along the length of the cable.

The cable assembly was terminated at one end with a high power fixed 50 ohm load.

The other end of the cable was mated to the signal source. The signal source consisted of a discrete frequency CW signal generator which was amplified to produce the desired high power levels. A coupler and power meter was placed before the cable assembly to verify the power input level. See Figure #1 for the test setup.

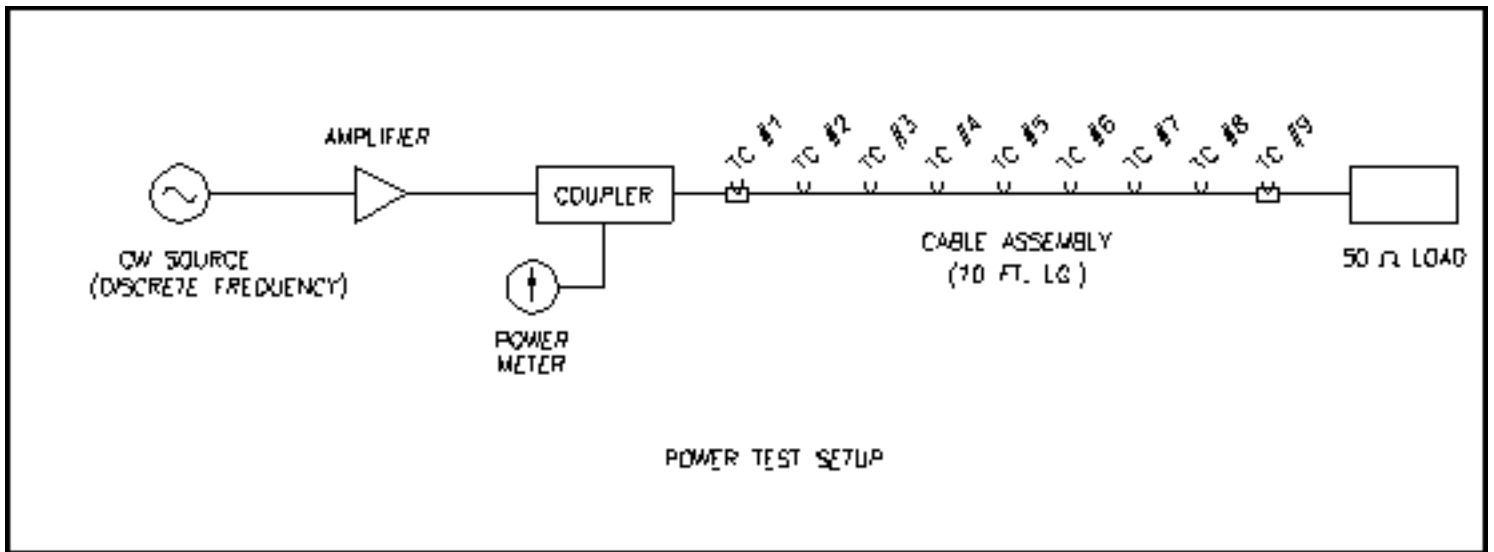

Figure 1

All nine thermocouple temperature readings were measured prior to power input. Then 100 watts of CW power at 18 GHz was injected into the test specimen. The power was maintained +/-2% until all thermocouples attached to the cable had reached a steady state. Steady state was defined as temperature change less than +/-1° within 5 minutes.

After steady state was reached, the temperature on each thermocouple was recorded and the injected power was increased. Additional power levels included 150 watts for all test specimens and 200 watts for some samples. After each power increment, all thermocouple temperatures were allowed to obtain steady state before measurements were recorded.

The maximum temperature recorded on the cable assembly at each input power level is indicated below.

<u>Serial Number</u>	<u>Description</u>	Temp (0° C) @		
		<u>100 watts</u>	<u>150 watts</u>	<u>200 watts</u>
96H1761	UFA 210B-0-0600-300300	43.1	56.0	66.0
96H1758	UFA 147A-0-0600-504504	48.6	61.4	56.9
96H1755	UFB 311A-0-0600-504504	30.0	37.0	42.7
96H1762	UFA 210B-0-0600-504504	36.4	49.3	Not tested
96H1760	UFA 210B-0-0600-504504	41.6	53.3	Not tested
96H1763	UFA 210B-0-0600-504504	37.1	47.6	Not tested
96H1765	UFA 210A-0-0600-504504	49.2	67.4	Not tested
96H1764	UFA 210B-0-0600-300300	33.9	46.7	Not tested
96H1766	UFA 210B-0-0120-300300	37.7	43.4	Not tested
96H1757	UFB 311A-0-0600-603603	34.3	42.3	51.2

After completion of the power handling test, all test specimens were tested for insertion loss and VSWR performance and were determined to meet Micro-Coax specifications.